

**CITY OF BROOKS
BYLAW NO. 23/04**

A BYLAW OF THE CITY OF BROOKS, IN THE PROVINCE OF ALBERTA, TO PROVIDE FOR THE ESTABLISHMENT AND OPERATION OF FIRE PROTECTION SERVICES

WHEREAS the *Municipal Government Act* RSA c.M-26 and regulations as amended, provides that the Council of a municipality may pass a Bylaw for the safety, health and welfare of people, and the protection of people and Property, and for services provided by or on behalf of the City;

AND WHEREAS the Council of the City of Brooks wishes to establish a fire service within the City and to provide for the efficient operation of such a fire service.

AND WHEREAS the Council of the City of Brooks wishes to regulate the use and setting of fires;

NOW, THEREFORE the Council of the City of Brooks, in the Province of Alberta duly assembled, enacts as follows:

1. NAME OF BYLAW

100. This Bylaw may be cited as the "Fire Bylaw".

2. DEFINITIONS

200. In this Bylaw:

201. "**Apparatus**" means any vehicle provided with machinery, devices, Equipment or materials for Firefighting as well as vehicles used to transport Firefighters or supplies;

202. "**Bylaw**" means the City of Brooks Bylaw No. 23/04 as may be amended from time to time;

203. "**Chief Administrative Officer**" means the Chief Administrative Officer of the City of Brooks regardless of any subsequent title that may be conferred on that Officer by Council or statute, or their designate;

204. "**City**" means the City of Brooks, a Municipal Corporation in the Province of Alberta, or the geographical area contained within the boundaries of the City of Brooks, as the context may require;

205. "**Council**" means the Council of the City of Brooks;

206. **“Dangerous Goods Product”** means those products or substances, which are regulated by the *Transportation of Dangerous Goods Act* and its *Regulations*;
207. **“Deputy Fire Chief”** means the Member appointed as Deputy Fire Chief who performs the duties and responsibilities of a Fire Chief when designated and who is also a Safety Codes Officer pursuant to the *Safety Codes Act*;
208. **“Designated Officer”** means a Designated Officer of the City whose authority includes inspections or enforcement of the City’s Bylaws;
209. **“Equipment”** means any tools, contrivances, devices or materials used by the Fire Department to combat an Incident or other emergency;
210. **“Fire”** means any combustible material in a state of combustion;
211. **“Fire Alarm System”** means a system designed to give early warning of a possible Fire in a building to the building occupants;
212. **“Fire Chief”** means the Member appointed as head of the Fire Department who is also a Safety Codes Officer pursuant to the *Safety Codes Act* and includes any person designated to act in their absence;
213. **“Fireworks”** means a device or devices containing gunpowder and other combustible chemicals that causes a spectacular explosion when ignited, used typically for display or in celebrations;
214. **“Fire Department”** means the department established by this Bylaw and includes any person duly appointed to the Fire Department;
215. **“Fire Department Property”** means all Property owned or controlled by the City and designated for use by the Fire Department, regardless of the source of the Property;
216. **“Fire Hazard”** means any condition, circumstance or event wherein the possibility of Fire is increased;
217. **“Fire Permit”** means a document issued pursuant to this Bylaw, on a form as set out in Schedule A, B or C as the case may require;
218. **“Fire Pit”** means a burning device to burn combustible material as described in the attachment to Schedule B;
219. **“Fire Protection”** means all aspects of Fire safety including but not limited to Fire prevention, Firefighting or suppression, pre-Fire planning, Fire investigation, public education and information, rescue or dangerous goods response, training, or other staff development;

220. **"Fire Protection Charge"** means any or all costs incurred by the Fire Department in providing Fire Protection;
221. **"Incident"** means a Fire or a situation where an explosion is imminent or other situation where there is a danger or possible danger to life or Property and to which the Fire Department has responded;
222. **"Member"** means any person who is a duly appointed Member of the Fire Department, including a part-time Member or Officer, and includes the Fire Chief and Deputy Fire Chief;
223. **"Member in Charge"** means the senior Member present on scene;
224. **"Officer"** means a Member appointed as a Fire Chief, Deputy Fire Chief, Captain or Lieutenant;
225. **"Open Air Fire"** means any Fire not contained within a building or structure and shall include Fire involving humus soil, piles of coal, farm produce, waste, bush, grass, seed, straw or any Fire that has escaped or spread from a building, structure, machine or vehicle and any Fire set for the purpose of thawing frozen ground or clearing land;
226. **"Owner"** means the person who has care and control or power of authority or can exercise powers and authority over a building;
227. **"Peace Officer"** means a Bylaw Enforcement Officer appointed by the City of Brooks pursuant to Section 555 of the *Municipal Government Act* and for the purpose of enforcement of this Bylaw, also includes a Peace Officer or a member of the Royal Canadian Mounted Police;
228. **"Property"** means any real or personal Property, which, without limiting the generality of the foregoing, includes land and structure; and,
229. **"Running Fire"** means a Fire burning without being under proper or any control of any person.

3. FIRE SERVICE

300. Council hereby establishes the Brooks Fire Department for the purpose of:
- 301. preventing and extinguishing Fires;
 - 302. investigating the cause of Fires;
 - 303. preserving life and Property and protecting persons and Property from injury or destruction by Fire;
 - 304. providing rescue services;

- 305. preventing, combating and controlling emergency Incidents;
- 306. carrying out Fire inspections;
- 307. fulfilling approved agreements with other municipalities or persons with respect to Fire Protection;
- 308. operating Apparatus and Equipment for extinguishing Fires or preserving life and Property;
- 309. mitigating Incidents relating to Dangerous Goods Products; and,
- 310. otherwise providing Fire Protection Services.

4. FIRE CHIEF

- 400. The Fire Chief shall be appointed by the Chief Administrative Officer.
- 401. The Fire Chief shall report to the Chief Administrative Officer or their designate.
- 402. The Fire Chief shall have complete responsibility and authority over the Fire Department, subject to the direction of Council and the Chief Administrative Officer or their designate and shall prescribe rules, regulations and procedures for the ongoing organization and administration of the Fire Department, including but not limited to:
 - 403. the use, care and protection of Fire Department Property;
 - 404. the appointment, recruitment, training, conduct, discipline, duties and responsibilities of the Members of the Fire Department;
 - 405. the efficient operation of the Fire Department; and,
 - 406. other duties and responsibilities as assigned by job description, policy or Bylaw.
- 407. Regulations, rules or standard operating procedures made pursuant to this Bylaw shall not be inconsistent with the laws of the Province of Alberta.
- 408. The Fire Chief shall:
 - 409. within budget approval and in accordance with any relevant policies, purchase or otherwise acquire Equipment, Apparatus, materials or supplies required for the operation, maintenance and administration of the Fire Department to be used in connection therewith; and,
 - 410. keep or cause to be kept, in proper form, records of all business transactions of the Fire Department, including the purchase or acquisition of Equipment, Apparatus, materials or supplies and records of Fires attended, actions taken in extinguishing Fires, inspections carried out and actions taken on account of inspections or any other records incidental to the operation of the Fire Department.

411. The Fire Chief, or in their absence, the Member in Charge, shall have control, direction and management of any Fire Department Apparatus, Equipment or manpower, assigned to an Incident and, where a Member is in Charge, they shall continue to act until relieved by the Fire Chief or the Deputy Fire Chief.
412. The Fire Chief or Member in Charge may, at an Incident, at their discretion, establish perimeters and keep persons from entering the area within the prescribed boundaries or limits unless authorized to enter by them.
413. The Fire Chief or Member in Charge may request a Peace Officer to enforce restrictions on persons entering within the boundaries or limits outlined in Subsection 412.
414. The Fire Chief or Member in Charge, at an Incident, is empowered to enter private Property and to take all steps they think is necessary in order to directly or indirectly combat, control or deal with an Incident, including, but not limited to:
 415. pass through or over buildings or Property whether adjacent or otherwise, to an Incident and remain in or on the building or Property and to cause Members of the Fire Department and the Apparatus and Equipment of the Fire Department to enter or pass through or over the building or Property and remain in or on the building or Property; and,
 416. cause the building, structure or thing to be wholly or partially pulled down, demolished, modified or otherwise removed.
417. The limits of the jurisdiction of the Fire Chief, Deputy Fire Chief, Officers and Members of the Fire Department will extend to the area and boundaries of the City of Brooks and no part of the Fire Apparatus shall be used beyond the limits of the City unless a written agreement is in place for supplying Fire Protection Services outside the City of Brooks.
418. The Fire Chief, and anyone acting in their absence, is hereby authorized to take whatever action they deem appropriate in the event that an emergency situation or emergency circumstance arises that is not provided for in this Bylaw. In the event that the Fire Chief, or anyone acting in their absence, takes action under this clause, the action taken shall be limited to those steps necessary to bring the emergency situation or emergency circumstance under control. Anyone taking action under this clause shall make a full report of the particulars to the Chief Administrative Officer or their designate within twenty-four (24) hours of the commencement of the action taken.

5. POWERS OF FIRE MEMBERS

500. Each Member shall have the authority and power to:

501. perform work relating to the extinguishing or controlling of the Incident or the operations to preserve life and Property and enter onto any Property for the purpose of extinguishing or controlling the Incident, at the discretion of the Fire Chief; and,
502. prevent interference with the efforts of persons engaged in the extinguishing of Fires or preventing the spread thereof by regulating the conduct of the public at or in the vicinity of any Incident.

6. POWERS OF OFFICERS

600. Officers in charge of an Incident shall have the authority and power to:
 601. commandeer the use of any Equipment for the purposes of fighting the Incident or for the purpose of preserving life or Property;
 602. perform work relating to the extinguishing or controlling the Fire or the operations to preserve life and Property and enter onto any Property for the purpose of extinguishing or controlling the Incident; and,
 603. prevent interference with the efforts of persons engaged in the extinguishing of Fires or preventing the spread thereof by regulating the conduct of the public at or in the vicinity of any Incident.

7. FIRE PROTECTION CHARGES

700. Upon providing Fire Protection on Property within or outside the City's boundaries, the City in its sole and absolute discretion may charge a Fire Protection Charge to the following, and all individuals charged are jointly and severally responsible for the Fire Protection Charge:
 701. the person causing or contributing to the Fire; or,
 702. the Owner or occupant of the Property.
703. The schedule of fees for Fire Protection Charges shall be as set out in Bylaw 23/05 or any amendments thereto or replacements thereof.
704. Fire Protection Charges shall be paid within thirty (30) days of being levied.
705. Collection of unpaid Fire Protection Charges may be undertaken by civil action in a Court of competent jurisdiction and any civil action does not invalidate any lien, which the City is entitled to on the Property in respect of which the indebtedness is incurred.

706. The Owner of a parcel to which Fire Protection is provided is liable for Fire Protection Charges incurred, and the City may add to the tax roll of the parcel of land all unpaid Fire Protection Charges.

8. CONTROL OF FIRE HAZARDS

800. If the Fire Chief finds within the City boundaries on privately owned land or occupied public land any condition that in their opinion constitutes a Fire Hazard they may order the Owner or the person in control of the land on which the Fire Hazard exists to reduce or remove the Fire Hazard within a fixed time and in a manner prescribed by the Fire Chief.
801. If the Fire Chief finds that the order they made pursuant to Subsection 800 has not been carried out, a Designated Officer may enter onto the land with any Equipment and any person it considers necessary and may perform the work required to eliminate or reduce the Fire Hazard.
802. The Owner or occupant of the land on which work was performed pursuant to Subsection 801 shall, upon demand, pay to the City a Fire Protection Charge, and in default of payment of the Fire Protection Charge, the City may add the Fire Protection Charge to the tax roll of the said land, which forms a special lien against the land in favour of the City, from the date it was added to the tax roll.

9. REQUIREMENT TO REPORT

900. The Owner or occupant of any Property containing a Dangerous Goods Product, which sustains an accidental or unplanned release of dangerous goods, shall immediately report to the Fire Department particulars of the release. The Owner or occupant of the Property shall provide such information regarding the release as the Fire Chief may require.

10. FIRE PERMITS

1000. No person shall offer for sale, purchase or ignite any low hazard Fireworks within the corporate limits of the City of Brooks.
1001. No person shall ignite any of the following without a permit:
- 1002. Open Air Fire;
 - 1003. high hazard Fireworks; and/or,
 - 1004. a Fire within a Fire Pit.
1005. An application for a Fire Permit shall be made to the Fire Chief or, in their absence, the Deputy Fire Chief in writing on the form prescribed in Schedule "A", "B" or "C", as appropriate. The Fire Chief or, in their absence, the Deputy Fire Chief shall receive and consider the application

and, after having done so, they may, in their absolute discretion, issue to the applicant a Fire Permit.

1006. Each application for a Fire Permit must be accompanied by the appropriate fee and must contain information set out in Schedule "A", or "B" or "C" as appropriate. A Fire Permit is not transferable.
1007. A person to whom any Fire Permit has been issued under Subsection 1005 shall, at all times, keep at least one (1) person over the age of eighteen (18) years in place to continuously supervise the Fire or Fireworks. For the purpose of this subsection, a Fire shall include, but not be limited to, any hot ashes or smoldering embers resulting from the Fire or Fireworks.
1008. When issuing any Fire Permit the Fire Chief or, in their absence, the Deputy Fire Chief may impose conditions considered appropriate.
1009. A Fire Permit issued pursuant to this Bylaw is valid for such period of time as shall be determined and set by the Fire Chief or, in their absence, the Deputy Fire Chief and endorsed on the Fire Permit, unless sooner suspended or cancelled pursuant to the provisions of this Bylaw.
1010. The Fire Chief or, in their absence, the Deputy Fire Chief may extend the period of time for which the Fire Permit is valid, provided the Fire Permit has not expired.
1011. The Fire Chief or, in their absence, the Deputy Fire Chief may, in their absolute discretion, suspend or cancel any Fire Permit at any time. A Fire Permit may be suspended or cancelled by advising a permit holder in person or by telephone.
1012. Upon issuing a suspension or cancellation notice pursuant to Subsection 1011 the Fire Permit being the subject of the notice is suspended or cancelled effective the date stipulated in the notice.

11. NO SMOKING AREA

1100. No person shall ignite or allow to burn any smoking material in a non-smoking area on City owned Property.

12. OFFENCES

1200. No person shall:
 1201. contravene any provision(s) of this Bylaw;
 1202. deposit, discard or leave any burning matter or substance where it might ignite other material and cause a Fire;

1203. provide false, incomplete or misleading information to the City or the Fire Department on or with respect to a Fire or Fire Permit application;
1204. impede, obstruct, or hinder a Member of the Fire Department, or other person assisting or acting under the direction of the Fire Chief or the Member in Charge at any Incident;
1205. damage or destroy Fire Department Apparatus, Equipment or Fire Department Property without proper authorization;
1206. falsely represent themselves as a Member or wear or display any Fire Department badge, cap, button, insignia or other paraphernalia for the purpose of such false representation;
1207. drive a vehicle over any Fire Department Apparatus or Equipment at an Incident, without the permission of the Fire Chief or the Member in Charge;
1208. obstruct or otherwise interfere with access roads or streets or other approaches to any Incident, Fire hydrant, cistern or body of water designated for Firefighting purposes or any connections provided to a Fire main, pipe, stand pipe, sprinkler system, cistern or other body of water designated for Firefighting purposes;
1209. use a Fire hydrant for the purpose of obtaining or discharging water from such hydrant, other than the employee of the City Public Works & Utilities Department or a Member of the Fire Department, without first receiving permission from an Official of the City's Public Works & Utilities Department or the Fire Department;
1210. enter the boundaries or limits at an Incident, of an area prescribed in accordance with Section 412, unless they have been authorized to enter by the Fire Chief or the Member in Charge;
1211. obstruct a Member from carrying out any function or activity related in any way to Fire Protection;
1212. allow an Open-Air Fire to be lit, unless that person is the holder of a subsisting Fire Permit or the Fire has been set by a Member for the purpose of training Members;
1213. have in his or her possession, sell, offer for sale, give away or otherwise distribute, discharge, Fire or set off high or low hazard Fireworks unless that person is the holder of a subsisting Fire Permit for the purposes of a Fireworks display or the Fireworks have been set by a Member for the purpose of training Members;

1214. permit a Fire to burn when a Fire is set in contravention of Subsections 1001 – 1004;
1215. either directly, or indirectly, personally or through an agent, servant or employee kindle a Fire or let it become a Running Fire on any land not their own Property or allowing a Running Fire to pass from their own Property to the Property of another;
1216. light a Fire without first taking sufficient precautions to ensure that the Fire can be kept under control at all times;
1217. light a Fire when the weather conditions are conducive to create a Running Fire;
1218. fail to take reasonable steps to control a Fire for the purpose of preventing it from becoming a Running Fire or from spreading onto Property other than their own;
1219. conduct an activity that involves the use of Fire that might reasonably be expected to be a nuisance or annoyance to a neighbour;
1220. conduct any activity that involves the use of a Fire, where smoke from the Fire will impede visibility of vehicular traffic or pedestrian traffic on any Highway as defined in the *Traffic Safety Act*, R.S.A. 2000, c.T-6, as amended;
1221. light a Fire on lands owned or controlled by the City except with the City's express written consent or in specifically designated or approved areas; and,
1222. make a building's Fire Alarm System inoperable, without first notifying the Fire Chief, unless the system is required to be made inoperative for maintenance or testing.

13. ENFORCEMENT:

1300. A Peace Officer is for the purposes of enforcement of this Bylaw, a Designated Officer of the City.
1301. Fines and penalties imposed on a conviction for an offence under this Bylaw are an amount owing to the City.
1302. The levying and payment of any fine or the imprisonment for any period provided in this Bylaw shall not relieve a Person from the necessity of paying any fees, charges or costs from which that Person is liable under the provisions of this Bylaw or any other Bylaw.

1303. Any person who breaches, contravenes or does not comply with any provision of the Bylaw is guilty of an offence and liable:
1304. upon the issuance of a Violation Tag to the specified penalty as listed on Schedule "D" attached to and forming part of this Bylaw; or,
1305. upon summary conviction to a fine of not less than the amount specified on Schedule "D" attached to and forming part of this Bylaw for each offence, exclusive of costs; or,
1306. to a fine of not more than \$10,000 or to imprisonment for not more than one (1) year, or to both fine and imprisonment.
1307. A Peace Officer is hereby authorized and empowered to issue a Violation Tag to any person who has contravened any provision of this Bylaw.
1308. A Violation Tag shall be deemed to be sufficiently served if:
1309. served personally on the accused; or,
1310. mailed to the address of the registered Owner of the property concerned or to the Person concerned; or,
1311. served personally upon the manager, secretary, receptionist or other officer or person apparently in charge at any Premises of the accused, or by mailing a copy to such accused.
1312. A Violation Tag shall state:
1313. the name of the person or registered Owner or other information to adequately identify the person;
1314. approximate location of where the offence took place;
1315. the offence;
1316. the penalty for the offence set out on Schedule "D" of the Bylaw;
1317. that the penalty shall be paid within fourteen (14) days from the issuance of the Violation Tag; and,
1318. any other information deemed necessary by the Chief Administrative Officer or by the provisions of the Act or the *Provincial Offences Procedure Act*, RSA 2000, c P-34 as amended.
1319. Where a breach of this Bylaw is of a continuing nature, each day on which it continues or is repeated shall constitute a separate offence and shall be liable to a separate penalty.

1320. Where a Violation Tag has been issued for breach of any provision of this Bylaw, the person to whom the Violation Tag is issued may, in lieu of being prosecuted for the offence, pay to the City the penalty specified on the Violation Tag.
1321. Nothing in the Bylaw shall prevent a Peace Officer from immediately issuing a Violation Ticket.
1322. If a Person upon whom a Violation Tag is served above fails to pay the voluntary payment within the time specified, a Peace Officer is hereby authorized and empowered to issue a Violation Ticket pursuant to Part II of the *Provincial Offences Procedure Act*, RSA 2000, c P-34, as amended, or as repealed and replaced from time to time.
1323. The Person to whom a Violation Ticket has been issued pursuant to the *Provincial Offences Procedure Act*, RSA 2000, c P-34, as amended, or as repealed from time to time, may plead guilty by making a voluntary payment in respect to the summons by delivering to the Provincial Court, on or before the initial appearance date, the Violation Ticket together with an amount equal to the specified penalty for the offence as provided for in Schedule "D" to this Bylaw.
1324. Any Person who is guilty by way of summary conviction of an offense under the provisions of this Bylaw shall be liable for a fine of not less than the amount specified for that particular breach of this Bylaw, plus associated court costs pursuant to Part II of the *Provincial Offences Procedure Act*, RSA 2000, c P-34, as amended, or as repealed from time to time.

Remedial Orders

1325. A Peace Officer is hereby authorized and empowered to issue a remedial order to any Person whom the Peace Officer has reasonable and probable grounds to believe has contravened any provision of this Bylaw.
1326. A remedial order written pursuant to this Bylaw may:
1327. direct a Person to stop doing something, or to change the way in which the Person is doing it;
1328. direct a Person to take any action or measures necessary to remedy the contravention of this Bylaw, and, if necessary, to prevent a reoccurrence of the contravention;
1329. state a time within which a Person must comply with the directions; and,

1330. state that if the Person does not comply with the directions within a specified time, the City will take the action or measures at the expense of the Person.
1331. A remedial order written pursuant to this Bylaw may be served:
1332. in the case of an individual:
1333. by physically delivering it to the Person; or,
1334. by mail addressed to the Person at their apparent place of residence or at any address for the Person on the tax roll of the City or at the Land Titles registry. A remedial order is deemed to be received seven (7) days after it is mailed.
1335. in the case of a company or corporation or other such entity:
1336. by physically delivering it to any director or officer of the company;
1337. by physically delivering it to a Person apparently in charge of an office of the company at an address held out by the company to be its address; or,
1338. by mail addressed to the registered office of the company. A remedial order is deemed to be received seven (7) days after it is mailed.
1339. If, in the opinion of a Peace Officer, service of the remedial order cannot be reasonably affected, or if the Peace Officer believes that the Owner and/or occupier of the Premises is evading service, the Peace Officer may post the remedial order in a conspicuous place on the Premises to which the remedial order relates, or on the private dwelling place of the Owner of the Premises, as registered at the Land Titles Office or on the municipal tax roll for the Premises, and the remedial order shall be deemed to be served upon the expiry of three (3) days after the remedial order is posted.
1340. Every person who fails to comply with a remedial order issued pursuant to this Bylaw within the time set out in the remedial order commits an offence.
1341. If the person to whom a remedial order has been issued fails to comply with the remedial order within the time specified therein, the City may take whatever steps are necessary to remedy the contravention of this Bylaw and the cost of doing so becomes a debt owing to the City by the Person to whom the order was issued.
1342. If, in the opinion of the Chief Administrative Officer, a contravention of this Bylaw requires immediate action, the City may perform any work necessary to address the contravention of this Bylaw without prior notice

or a remedial order and all costs incurred by the City will be payable by the person alleged to have contravened this Bylaw.

14. REPEAL

1400. That Bylaw No. 11/04 and any amendments thereto are hereby repealed.

15. SEVERABILITY

1500. It is the intention of Council that each separate provision of this Bylaw shall be deemed independent of all other provisions herein and it is the further intention of Council that if any provision of this Bylaw is declared invalid, all other provisions hereof shall remain valid and enforceable.

16. EFFECTIVE DATE

1600. This Bylaw shall take effect at the date of final passing thereof.

Read a first time this 20th day of March, 2023.

Read a second time this 20th day of March, 2023.

Read a third time and finally passed this 20th day of March, 2023.

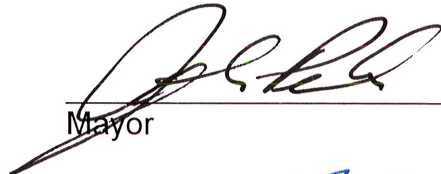

Mayor



Chief Administrative Officer

**SCHEDULE "A"
CITY OF BROOKS
APPLICATION FOR A BURNING PERMIT
BYLAW NO. 23/04**

NAME: _____

ADDRESS: _____

ADDRESS OF PROPERTY FOR WHICH APPLICATION IS REQUESTED:

This permit is good for the burning of dried wood, leaves or grass only.

\$20.00 Application Fee Paid?: _____

Issue Date: _____

Burn Date: _____

Expiry Date: _____

If the following conditions are not adhered to at all times the Burning Permit may be withdrawn and the Fire extinguished.

- Size of lot shall be .35 acres or larger.
- Burning piles shall be no closer than 15 meters (50 feet) to a building or structure.
- Burning is restricted to daylight hours.
- Burning is to be supervised at all times by a responsible person over the age of eighteen (18) years.
- A sufficient supply of water to extinguish the Fire if conditions are such that a Fire would become uncontrollable.
- Burning piles shall be no larger than 1.5 meters (5 feet) in diameter and 0.6 meters (2 feet) in height.
- BEFORE BURNING - Call Fire Department Dispatch Fire Permit Line 1-877-507-7011.

Signature of Applicant: _____

Signature of Issuer: _____

On signature of this permit by the applicant, the City of Brooks is indemnified from any civil or criminal action resulting from damage by Fire due to the applicant not adhering to the listed conditions.

**SCHEDULE "B"
CITY OF BROOKS
APPLICATION FOR A PERMIT TO CONSTRUCT AND OPERATE A BURNING DEVICE
BYLAW NO. 23/04**

Applicant Name: _____

Address of Property Affected: _____

Mailing Address (if different): _____

Approved Device _____

Fee Paid? _____

Definitions:

Approved Device - A device or appliance specifically made for the purpose of containing a Fire which bears a proper approval label from the Underwriters Laboratory of Canada, or such other approving agency as designated by the Fire Chief. In all cases, the device or appliance shall meet the requirements of all legislation, codes and regulations pertaining to such devices or appliances.

Fire Pit - A non-commercial appliance or device used specifically for the purpose of burning combustible materials.

Process:

No person shall construct, erect, locate or use an approved device or a Fire Pit within the City of Brooks until a permit has been obtained from the Fire Chief. No person shall alter such device for which a permit has been issued without the consent of the Fire Chief.

A person requiring such a permit shall submit drawings and details to the Fire Chief with the application for a permit. Once the permit is approved the applicant shall keep the device in good condition.

A one-time fee of \$30.00 shall be charged with the application for an approved burning device.

Signature of Applicant

Fire Chief

Date Permit Issued

SCHEDULE "B"
CITY OF BROOKS
APPLICATION FOR A PERMIT TO CONSTRUCT AND OPERATE A BURNING DEVICE
BYLAW NO. 23/04

The City of Brooks regulates the construction and operation of Burning Devices, which includes Fire Pits under Bylaw 23/04.

Fire Pit applications are available for a one-time fee of \$30.00 (provided no alterations or relocations of the fire pit are made). Ownership of a Fire Pit is not transferable. Attached to the applications are the regulations, as follows, and a sample design plan.

- Fire Pit shall not be constructed over any underground utility;
- There shall be 3m (10') between the eve of the nearest building and the closest edge of the Fire Pit;
- Fire Pit shall not be constructed within 3m (10') of a fence or any other combustible material; and,
- Natural gas fired approved devices may be located closer than 3m (10') from combustible material but in no case shall such a device be located contrary to the manufacturer's recommendations.

Only seasoned dry wood can be burned in a Fire Pit and this device shall not be used for burning of green wood, garbage or other such items. The Fires are to be kept small and safe and a supply of water shall be at close hand. A spark retention screen covering the entire top of the Fire Pit shall be in place at all times when the Fire Pit is being burned.

Application for Fire Pits within mobile home parks must also have the approval of the mobile home park manager.

If you do not have a signed, approved Fire Pit Permit or you are not following the above rules and regulations please do not use your Fire Pit and contact the Fire Hall during normal business hours.

SCHEDULE "B"
CITY OF BROOKS
APPLICATION FOR A PERMIT TO CONSTRUCT AND OPERATE A BURNING DEVICE
BYLAW NO. 23/04

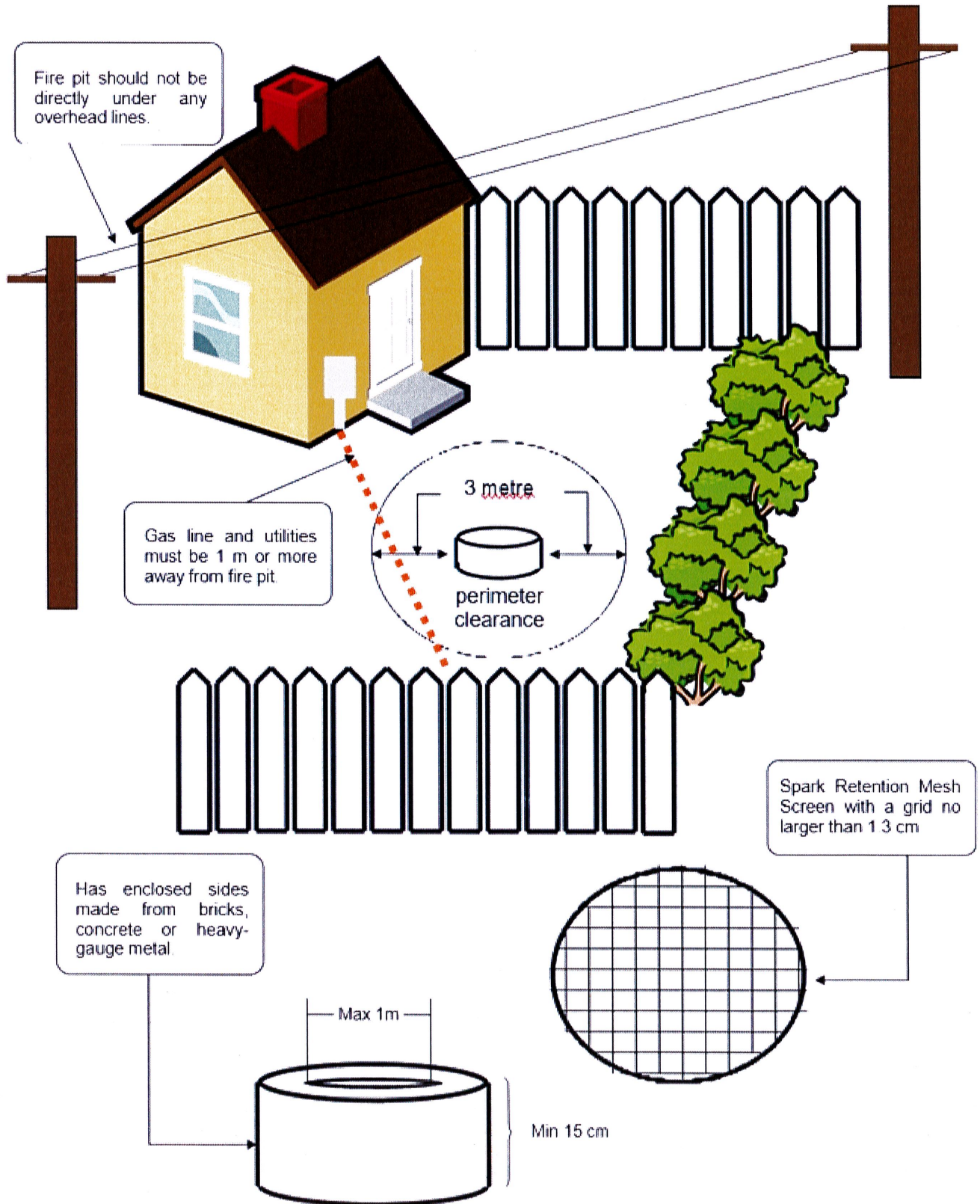

SCHEDULE "B"
CITY OF BROOKS
APPLICATION FOR A PERMIT TO CONSTRUCT AND OPERATE A BURNING DEVICE
BYLAW NO. 23/04

Burning Device Construction Guidelines

Side View

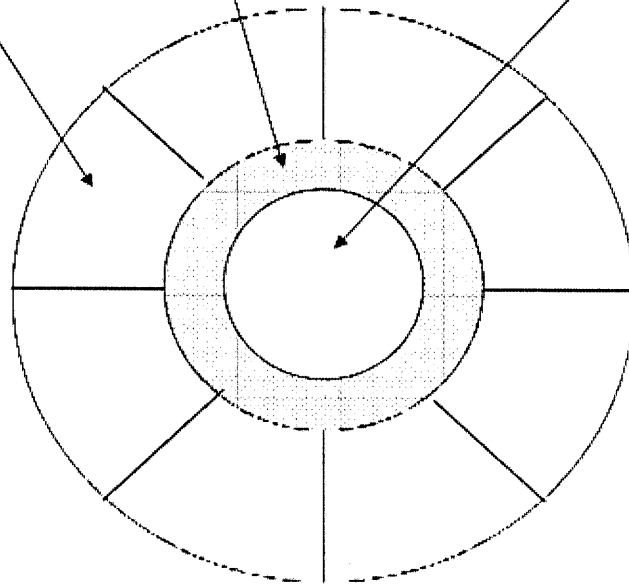
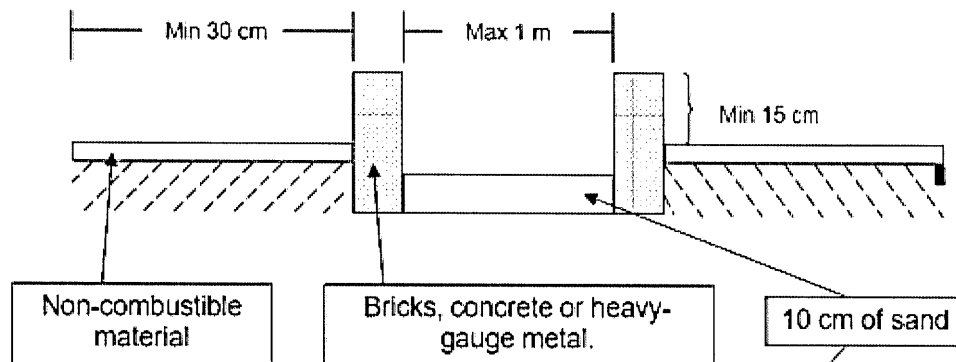

Overhead View

**SCHEDULE "C"
CITY OF BROOKS
ALBERTA FIRE CODE
FIREWORKS DISPLAY PERMIT**

PERMIT NO. _____

APPLICANT NAME: _____

ADDRESS: _____

REPRESENTING:

The applicant is hereby authorized to handle, discharge, Fire, set-off or display low or high hazard Fireworks on

_____ at _____
(date & time) (specific location where Fireworks will be displayed)

within the Province of Alberta.

This permit is subject to cancellation for any breach of the *Alberta Fire Code* or any of the following conditions and precautions required as a condition of this permit.

CONDITIONS AND PRECAUTIONS:

A diagram of the discharge/set-off/display site is to be provided on the back of this page.

Date

Signature of Safety Codes Officer Having Jurisdiction

Signature of Applicant

Fireworks Supervisor's Card No. & Expiry Date

**SCHEDULE "D"
PENALTIES**

<u>Subsection</u>	<u>Offence</u>	<u>Penalty</u>	<u>Second or Subsequent Offence Within 1 Year</u>
900.	Failure to report an accidental or unplanned release of a Dangerous Goods Product	\$200.00	\$500.00
1100.	Burn or ignite smoking material in a non-smoking area on City owned Property	\$ 50.00	\$100.00
1201.	Contravene any provisions of this Bylaw not otherwise in this schedule	\$100.00	\$200.00
1202.	Deposit, discard or leave any burning matter or substance where it might ignite other material and cause a Fire	\$ 50.00	\$100.00
1203.	Provide false, incomplete or misleading information to the City or the Fire Department on or with respect to a Fire or Fire Permit application	\$200.00	\$500.00
1204.	Impede, obstruct, or hinder a Member of the Fire Department, or other person assisting or acting under the direction of the Fire Chief or the Member in Charge at any Incident	\$200.00	\$500.00
1205.	Damage or destroy Fire Department Apparatus, Equipment or Fire Department Property	\$200.00	\$500.00
1206.	Falsely represent themselves as a Member or wear or display any Fire Department badge, cap, button, insignia or other paraphernalia for the purpose of such false representation	\$200.00	\$500.00
1207.	Driving a vehicle over any Fire Department Apparatus or Equipment at an Incident without the permission of the Fire Chief or the Member in Charge	\$200.00	\$500.00
1208.	Obstruct or otherwise interfere with access roads or streets or other approaches to any Incident, Fire hydrant, cistern or body of water designated for Firefighting purposes or any connections provided to a Fire main, pipe, stand pipe, sprinkler system, cistern or other body of water designated for Firefighting purposes	\$200.00	\$500.00

**SCHEDULE "D"
PENALTIES**

<u>Subsection</u>	<u>Offence</u>	<u>Penalty</u>	<u>Second or Subsequent Offence Within 1 Year</u>
1209.	A person, other than an employee of the City Public Works & Utilities Department or a Member of the Fire Department, using a fire hydrant for the purpose of obtaining or discharging water from such hydrant, without first receiving permission from an Official of the City's Public Works & Utilities Department or the Fire Department	\$200.00	\$500.00
1210.	Entering the boundaries or limits of an area prescribed in accordance with Subsection 412 unless they have been authorized to enter by the Fire Chief or the Member in Charge	\$200.00	\$500.00
1211.	Obstructing a Member from carrying out any function or activity related in any way to Fire Protection	\$500.00	\$1,000.00
1212.	Allowing an Open Air Fire to be lit, unless that person is the holder of a permit for a Fire Pit or outdoor Fire place or the Fire has been set by a Member for the purpose of training Members	\$ 50.00	\$100.00
1213.	Having in their possession, to sell, offer for sale, give away or otherwise distribute, discharge, Fire or set off high or low hazard Fireworks unless that person is the holder of a subsisting Fire Permit for the purposes of a Fireworks display or the Fireworks have been set by a Member for the purpose of training Members	\$200.00	\$500.00
1214.	When a Fire is set in contravention of Subsections 1001 – 1004	\$ 50.00	\$100.00
1215.	Either directly, or indirectly, personally or through an agent, servant or employee kindle a Fire or let it become a Running Fire on any land not his or her own Property or allow a Running Fire to pass from their own Property to the Property of another	\$100.00	\$200.00

**SCHEDULE "D"
PENALTIES**

<u>Subsection</u>	<u>Offence</u>	<u>Penalty</u>	<u>Second or Subsequent Offence Within 1 Year</u>
1216.	Light a Fire without first taking sufficient precautions to ensure that the Fire can be kept under control at all times	\$100.00	\$200.00
1217.	Light a Fire when the weather conditions are conducive to create a Running Fire	\$100.00	\$200.00
1218.	Failing to take reasonable steps to control a Fire for the purpose of preventing it from becoming a Running Fire or from spreading onto Property other than their own	\$100.00	\$200.00
1219.	Conducting an activity that involves the use of Fire that might reasonably be expected to be a nuisance or annoyance to a neighbour	\$ 50.00	\$100.00
1220.	Conducting any activity that involves the use of a Fire, where smoke from the Fire will impede visibility of vehicular traffic and pedestrian traffic on any Highway as defined in the <i>Traffic Safety Act</i> , R.S.A. 2000, c.T.-6, as amended	\$100.00	\$200.00
1221.	Light a Fire on lands owned or controlled by the City except with the City's express written consent or in specifically designated or approved areas	\$100.00	\$200.00
1222.	Make a building's Fire Alarm System inoperable, without first notifying the Fire Chief, unless the system is required to be made inoperative for maintenance or testing	\$500.00	\$1,000.00